



HEB32K



HEB32K + WB0VA2

- Indoor/Outdoor installations
- Extruded aluminium body, epoxy painted
- Hinged, removable body
- Double mounting option: regular or feed-through brackets
- Weatherproof Standard IP66 (with cable-glands or optional sealing gaskets)

New design, weatherproof housing for outdoor installations. Its dimensions make it suitable for several 1/2", 1/3" and 1/4" CCD cameras equipped with a wide range of lenses. Made of extruded and die-cast aluminium, it is provided with an innovative opening system which allows access to the housing's interior; the body and the sunshield slide forward and hang in place, while the unit remains fixed allowing access to the camera from all angles. This can be done from either sides for a rapid installation and easy adjustment.

Its weatherproof features are ensured by the EPDM-rubber gaskets and by 2 PG9 and 1 PG11 cable glands or by the sealing gaskets, when installed with bracket with internal cable management. The rear mounting bracket offers vandal-proof protection due to the internal cable channel for concealed power and video cables.

A wide range of accessories is available, including sunshield, normal and fan-assisted heater, blower kit and camera power supply.

Further, it is also possible to install a blower including an air filter replacing one of the cable glands (not suitable in case of using the bracket with internal cable channel).

The accessories are supplied factory installed or as a simple upgrade kit.

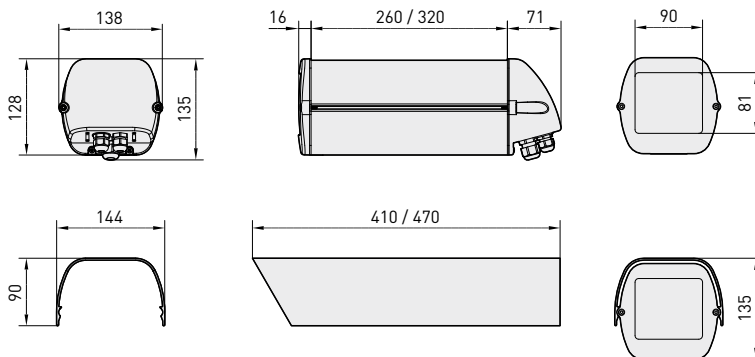

The values are in millimeters.

TECHNICAL DATA

HEB					
Model	Sunshield	Heater 115/230V AC	Heater 12V DC/24V AC	Fan assisted heater 24V AC	Max consumption
HEB26D0A000B					
HEB26K0A000B	•				
HEB26K1A000B	•	•			40W
HEB26K2A000B	•		•		20W
HEB32D0A000B					
HEB32K0A000B	•				
HEB32K1A000B	•	•			40W
HEB32K2A000B	•		•		20W
HEB32K2A015B	•			•	24W

GENERAL

Die-cast aluminium back and front cover plates
 Extruded aluminium body, external slide and sunshield
 Epoxypolyester powder painted colour RAL9002
 Stainless steel external screws
 Supplied with instruction manual, desiccant bag, accessories for camera and lens mounting

MECHANICAL

3 removable cable glands: 2xPG9 and 1xPG11
 Glass window (BxH): 90x81mm (3.5x3.2in)
 Internal usable area (BxH): 90x85mm (3.5x3.3in)

Internal usable length without accessories

HEB26	260mm (10.2in)
HEB32	320mm (12.6in)

Internal usable length with heater and/or power supply, or heater and/or blower

HEB26	190mm (7.5in)
HEB32	250mm (9.8in)

ELECTRICAL

Heater Ton 15°C+/-3°C (59°F +/-5°F) Toff 22°C+/-3°C (71°F +/-5°F)

- IN 12V DC/24V AC, consumption 20W max
- IN 115/230V AC, consumption 40W max

Blower kit with thermostat and air filter, Ton 35°C+/-3°C (95°F+/-5°F) Toff 20°C+/-3°C (71°F+/-5°F) and back cover

- IN 12V DC, consumption 4W max
- IN 24V AC, consumption 4W max
- IN 230V AC, consumption 4W max, complete with voltage transformer

Not compatible with bracket with internal cable channel

Camera power supply

- IN 100-240V AC - OUT 12V DC, 50/60 Hz, 1A
- IN 230V AC - OUT 24V AC, 50Hz, 400mA

ACCESSORIES

OHEBS26A000	Sunshield for HEB26
OHEBS32A000	Sunshield for HEB32
OHEH09B	Heater 12V DC/24V AC
OHEH10B	Heater 115/230V AC
OHEBVF1	Blower kit with thermostat air filter IN 12V DC
OHEBVF2	Blower kit with thermostat air filter IN 24V AC
OHEBVF3	Blower kit with thermostat air filter IN 230V AC
OHEPS01B	Wide range camera power supply IN 100-240V AC - OUT 12V DC
OHEPS02B	Camera power supply IN 230V AC - OUT 24V AC
OHEGBB	Weatherproof junction box IP55
IR50	IR illuminator 50W

RELATED PRODUCTS

WBJA	Wall bracket with ball joint
WBMA	Wall bracket with ball joint
WBOVA2	Wall bracket with internal cable channel
WBOV3A2	Wall bracket with internal cable channel, support plate and integrated junction box
WCM3A	Ceiling bracket with ball joint
WCM5A	Ceiling bracket with ball joint
WCM4A2	Ceiling bracket with internal cable channel
WFWCA	Column mount with ball joint
OWBIP1	Kit special gasket to allow protection IP66 for WBOVA2 and WCM4A2
PTH300	Pan&Tilt series
PTH900	Pan&Tilt series

ENVIRONMENT

Indoor / Outdoor
 Operating temperature with heater: -20°C / +50°C (-4°F / +122°F)
 Resistant to the salt-air fog until 1000 hours (according to ISO9227)

COMPLIANCE TO

CE according to EN61000-6-3, EN 60065, EN50130-4
 IP66 according to EN 60529 with cable glands
 IP66 according to EN 60529 with special gasket and bracket with internal cable channel
 IP54 according to EN 60529 with bracket with internal cable channel

SPARE PARTS LIST

DOTHE01	Spacers for camera and lens
OHEBMAN	Cable glands, gaskets and screws
OHBCEFA04	Front cover with screws and gaskets
OHBFP04B	Back cover with cable glands, screws and gaskets

	Unit Weight:	Package Weight:	Package Dimension (BxHxL):	Master Carton:
	HEB26K1 2.7kg / 5.9lb	HEB26K1 3kg / 6.6lb	HEB26K1 15.5x14x43cm / 6.1x5.5x16.9in	HEB26K1 10 units
	HEB32K1 3.2kg / 7lb	HEB32K1 3.5kg / 7.7lb	HEB32K1 16.5x15.5x49cm / 6.4x6.1x19.3in	HEB32K1 10 units